

UNOFFICIAL TRANSLATION



STATE TAX
INSPECTORATE

STATE TAX INSPECTORATE UNDER THE MINISTRY OF
FINANCE OF THE REPUBLIC OF LITHUANIA

SPECIFICATION OF THE XML SCHEMA DEFINITION OF I.SAF DATA FILE

Version 1.0

58 pages

VILNIUS
1 April 2016

Versions of the document

Date	Version	Description of amendments to the document
1 April 2016	1.0	Full version of the document



Content

1	TERMS.....	5
2	INTRODUCTION	5
3	GENERAL CONCEPT OF I.SAF DATA FILE	6
4	I.SAF XSD VERSIONS.....	7
5	I.SAF XSD DEFINITION.....	8
5.1	ISAFFILE.....	9
5.1.1	Header	10
5.1.1.1	FileDescription	11
5.1.1.1.1	SelectionCriteria.....	14
5.1.2	MasterFiles.....	15
5.1.2.1	Customer (Customers).....	16
5.1.2.2	Supplier (Suppliers).....	19
5.1.3	SourceDocuments	23
5.1.3.1	Invoice (PurchaseInvoices).....	25
5.1.3.1.1	SupplierInfo	28
5.1.3.1.2	References.....	32
5.1.3.1.3	DocumentTotal (DocumentTotals)	33
5.1.3.2	Invoice (SalesInvoices)	37
5.1.3.2.1	CustomerInfo	41
5.1.3.2.2	References.....	44
5.1.3.2.3	DocumentTotal (DocumentTotals)	45
5.1.3.3	SettlementsAndPayment (SettlementsAndPayments)	49
5.1.3.3.1	Payment	51
5.1.3.3.2	ReferencesToInvoice	54
5.2	DESCRIPTION OF SIMPLE TYPES.....	56

List of figures

Figure No 1.	General concept of i.SAF data file	6
Figure No 2.	Summary structure of i.SAF data file	7
Figure No 3.	General structure of i.SAF XSD - i.SAF (1).....	8
Figure No 4.	General structure of i.SAF XSD - i.SAF(2).....	9
Figure No 5.	i.SAF XSD -ISAFFile	9
Figure No 6.	i.SAF XSD - Header	10
Figure No 7.	i.SAF XSD - FileDescription.....	11
Figure No 8.	i.SAF XSD -SelectionCriteria	14
Figure No 9.	i.SAF XSD - MasterFiles	15
Figure No 10.	i.SAF XSD - Customer (Customers).....	16
Figure No 11.	i.SAF XSD - Supplier (Suppliers).....	19
Figure No 12.	i.SAF XSD - SourceDocuments	23
Figure No 13.	i.SAF XSD - Invoice (PurchaseInvoices)	25
Figure No 14.	i.SAF XSD - SupplierInfo.....	29
Figure No 15.	i.SAF XSD - References	32
Figure No 16.	i.SAF XSD - DocumentTotal (DocumentTotals).....	33
Figure No 17.	i.SAF XSD - Invoice (SalesInvoices).....	37
Figure No 18.	i.SAF XSD - CustomerInfo	41
Figure No 19.	i.SAF XSD - References	44
Figure No 20.	i.SAF XSD - DocumentTotal (DocumentTotals).....	46
Figure No 21.	i.SAF XSD - SettlementsAndPayment (SettlementsAndPayments)	49
Figure No 22.	i.SAF XSD - Payment	51
Figure No 23.	i.SAF XSD - ReferencesToInvoice	54
Figure No 24.	Simple types (1).....	56

Figure No 25. <i>Simple types (2)</i>	57
---	----

List of tables

Table No 1. <i>i.SAF XSD versions</i>	7
Table No 2. <i>FileDescription</i> elements.....	12
Table No 3. <i>SelectionCriteria</i> elements	14
Table No 4. <i>MasterFiles</i> elements	15
Table No 5. <i>Customer (Customers)</i> elements.....	16
Table No 6. <i>Supplier (Suppliers)</i> elements.....	19
Table No 7. <i>SourceDocuments</i> elements.....	23
Table No 8. <i>Invoice (PurchaseInvoices)</i> elements	26
Table No 9. <i>SupplierInfo</i> elements	29
Table No 10. <i>References</i> elements	32
Table No 11. <i>DocumentTotal (DocumentTotals)</i> elements	34
Table No 12. <i>Invoice (SalesInvoices)</i> elements	37
Table No 13. <i>CustomerInfo</i> elements	42
Table No 14. <i>References</i> elements	44
Table No 15. <i>DocumentTotal (DocumentTotals)</i> elements	46
Table No 16. <i>SettlementsAndPayment (SettlementsAndPayments)</i> elements.....	49
Table No 17. <i>Payment</i> elements	52
Table No 18. <i>ReferencesToInvoice</i> elements.....	55
Table No 19. <i>Simple types</i>	57

1 Terms

Term/Abbreviation	Meaning/Explanation
i.MAS	Advanced tax administration information system.
i.SAF	i.MAS subsystem of e-invoices through which the data of registers of received and issued VAT invoices are provided and e-services are supplied.
TP	Taxpayer.
VAT payer	Taxpayer who is registered for VAT purposes in Lithuania or other Member State of the European Union and to whom the VAT payer's code has been assigned.
Subject	A person whose register data are provided in i.SAF data file.
VAT	Value added tax.
STI, STI under MoF	State Tax Inspectorate under the Ministry of Finance of the Republic of Lithuania.
Invoice, VAT invoice	Received or issued VAT invoice the data of which are provided in i.SAF data file.
XML	Extensible Markup Language.
i.SAF XSD	XML Schema Definition of i.SAF data file.
i.SAF data file	XML format data file of registers provided in i.SAF.
IS	Information systems.
Legend ("Requirements for completion" column):	
*	Mandatory element, value may be optional.
**	One element or several elements from the group or the whole group of elements shall be selected. When the element has no value, it may be optional in i.SAF data file, except where the explanation of the filling in of the element value specifies that the value "ND" of the element shall be entered.
***	Mandatory element, value must be entered.

Other terms used in this document shall correspond to the terms used in the Law of the Republic of Lithuania on Value Added Tax and other legal acts.

2 Introduction

The document has been drawn up in observance of the Rules for the processing and providing the data of VAT invoice registers (hereinafter - Rules) approved by Order No VA-28 of the Head of the State Tax Inspectorate under the Ministry of Finance of the Republic of Lithuania of 25 March 2016. The Rules specify the requirements of the procedure and time limits for the processing and providing to the STI of the data of VAT invoice registers (hereinafter - registers).

The Rules specify that the register data shall be provided to the STI electronically by:

- providing i.SAF data file in i.SAF;
- using the web service aimed at the submission of i.SAF data file;
- entering to i.SAF the data from registers;
- issuing VAT invoices directly in i.SAF.

A detailed structure and requirements of i.SAF data file are provided in the definition of i.SAF data file. i.SAF data file shall be created and completed following the requirements of i.SAF XSD. The purpose of this document is to detail i.SAF XSD, define the elements of i.SAF XSD, the features of elements and the rules for entering the values of elements.

i.SAF XSD and the definition of i.SAF data file shall be published on the website of the STI <http://www.vmi.lt/cms/pvm-saskaitu-fakturu-registru-duomenu-tvarkymo-ir-pateikimo-taisykliu-projektas>.

3 General concept of i.SAF data file

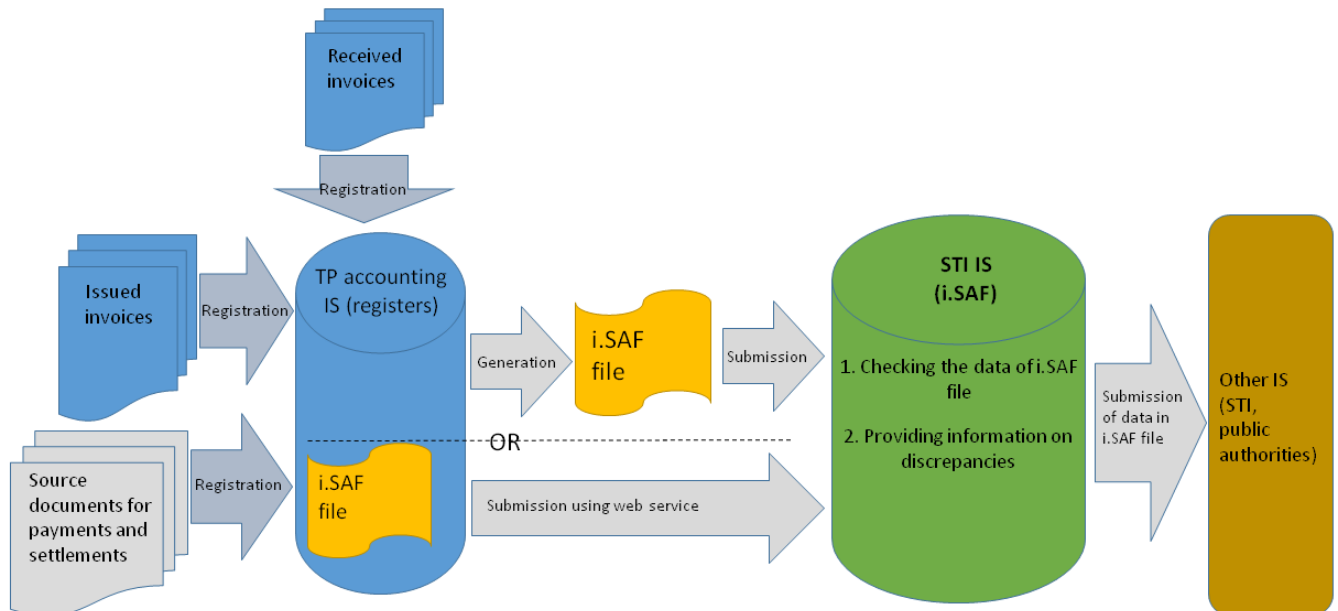

Figure No 1. General concept of i.SAF data file

i.SAF data file shall be generated in the taxpayer's accounting or other information system(s) used by the taxpayer according to the data of received and issued invoices registered in such information system(s) and according to the data of payments and settlements.

The structure of i.SAF data file shall consist of three parts: the header, the master file and data of source documents:

1. The header consists of the general information on the person whose registers are provided, tax period, file type, etc.;

2. The master file consists of data from registers of issued and received VAT invoices that are linked to the data of source documents by the unique code of the buyer and/or supplier used in the accounting system of the entity. The completion of the master file shall be recommended when many VAT invoices with the same buyer or supplier are registered over the tax period. The master file may be not entered, but in that case the register data of buyers and suppliers must be presented in the data of source documents;

3. The data of source documents consist of the data from registers of received and issued VAT invoices and payment details. The data of source documents may be not entered, if no VAT invoices were received or issued during the tax period (in that case only the header of i.SAF data file shall be filled in). The provision of payment details shall be recommended when the entity wishes to use the service of the preparation of a preliminary VAT return.

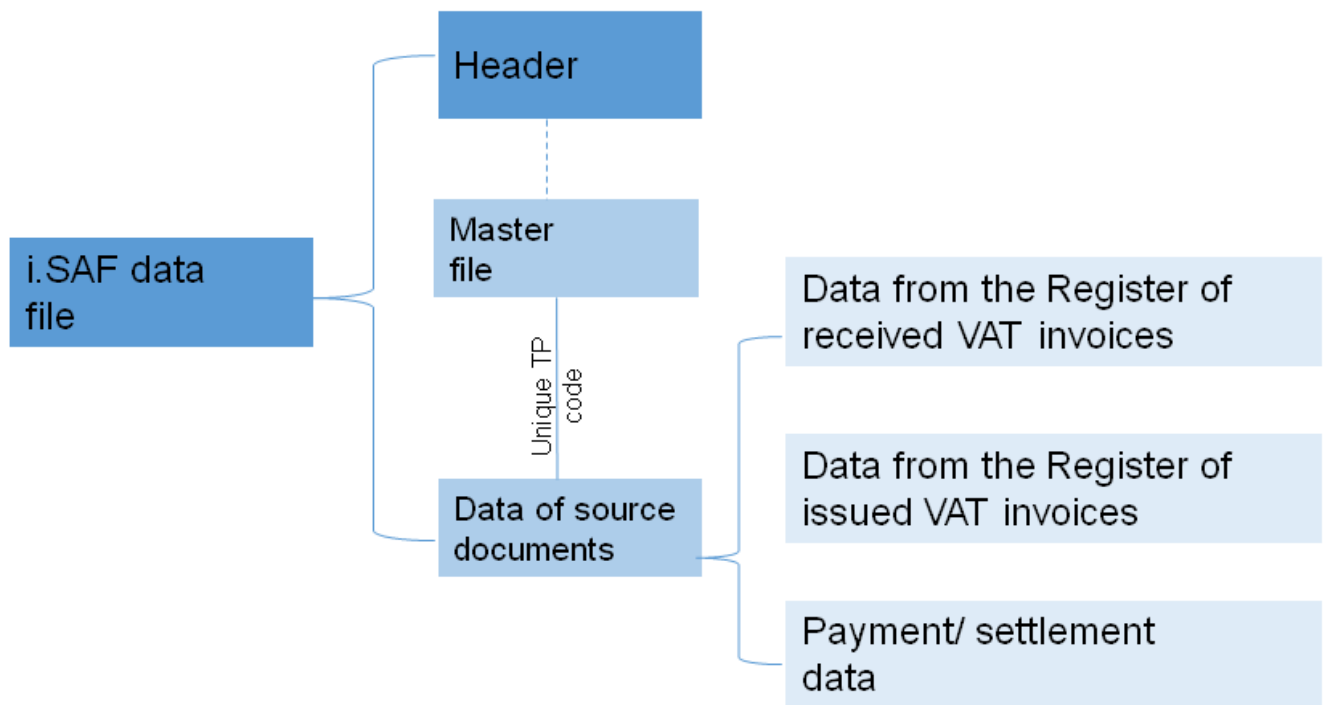

Figure No 2. Summary structure of *i.SAF data file*

4 i.SAF XSD versions

Table No 1. i.SAF XSD versions

Date	Version	File name	Description of amendments to the Version
1 April 2016	1.0	iSAF_1_0.xsd	Full version of i.SAF XSD.

5 i.SAF XSD definition

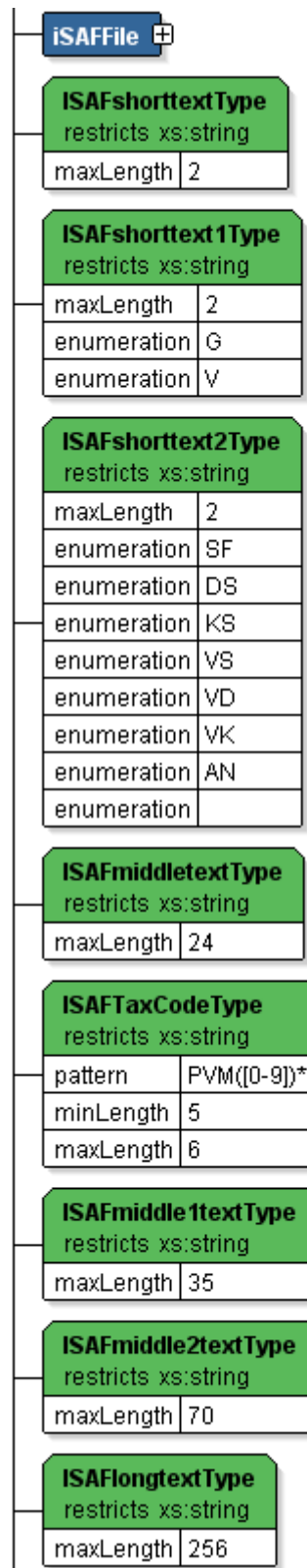

Figure No 3. General structure of i.SAF XSD - i.SAF (1)

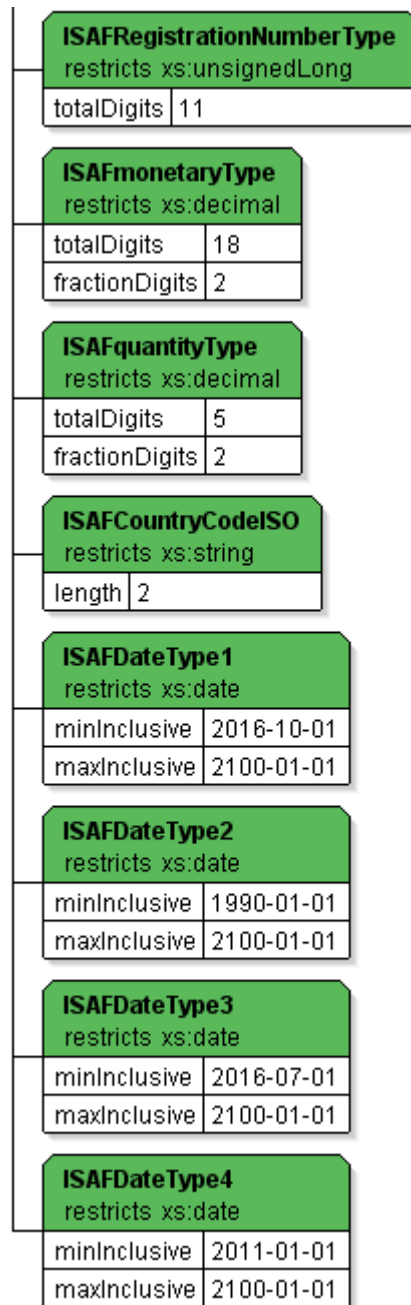

Figure No 4. General structure of i.SAF XSD - i.SAF(2)

5.1 ISAFFile

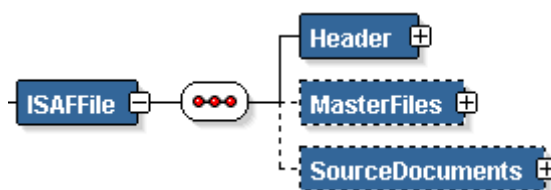

Figure No 5. i.SAF XSD - ISAFFile

5.1.1 Header

Figure No 6. i.SAF XSD - *Header*

5.1.1.1. FileDescription

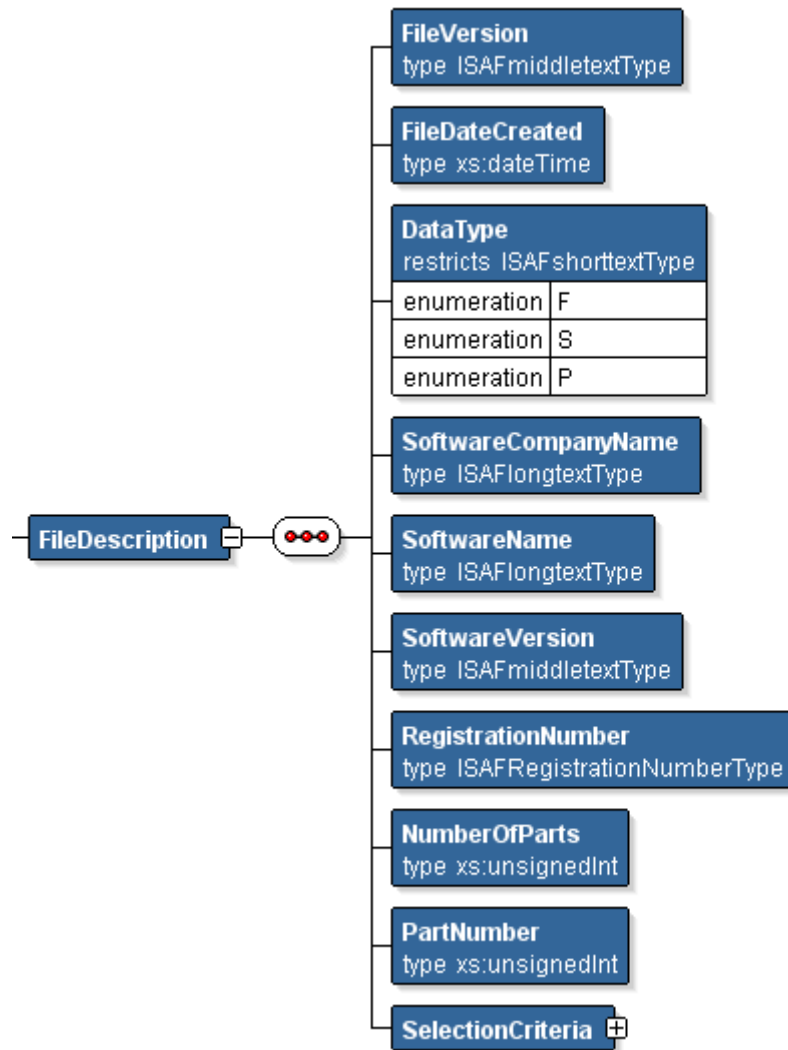

Figure No 7. i.SAF XSD - FileDescription

Table No 2. *FileDescription* elements

Element index	Name of the element	Short description of the element	Explanation of the element value to be filled in and verification rules	Requirements for completion	Simple type	Type	Length
1.1.	<i>FileVersion</i>	File version	XML version of the file. It should coincide with the version of the respective description of XML structure of the file (XSD).	***	ISAFmiddletextType	string	24
1.2.	<i>FileDateCreated</i>	Date and time of creation of the file	Date and time of creation of the file.	***		dateTime	
1.3.	<i>DataType</i>	Type of data	The type of provided data shall be indicated (F - full file (registers of received and issued VAT invoices), S - register of received VAT invoices, P - register of issued VAT invoices). An F type file may be adjusted with an F type file, an S type file may be adjusted with an S type file, a P type file may be adjusted with a P type file. Selecting only from the list values.	***		string	2
1.4.	<i>SoftwareCompany</i> <i>SoftwareName</i>	Name of the software company	Name of the software company.	*	ISAFlongtextType	string	256
1.5.	<i>SoftwareName</i>	Software name	Name of the software.	*	SAFLongtextType	string	256

1.6.	<i>SoftwareVersion</i>	Software version	Software version.	*	ISAFmiddletextType	string	24
1.7.	<i>RegistrationNumber</i>	Registration number	Taxpayer identification number (code) in the Register of Taxpayers. Positive integer.	***	ISAFRegistrationNumberType	unsignedLong	11
1.8.	<i>NumberOfParts</i>	Number of parts	Number of parts of one type file of the tax period. If the file is not divided into parts, the number 1 shall be indicated. Positive integer.	***		unsignedInt	
1.9	<i>PartNumber</i>	Part of the file	The number of the part of one type file of the tax period. If the file is not divided into parts, the number 1 shall be indicated. If the file is divided into several parts (e.g. 5), the number of the part shall be indicated (e.g. 1, 2, 3, 4 or 5). Positive integer.	***		unsignedInt	
1.10.	<i>SelectionCriteria</i>	Tax period	The period of declaration of VAT the register data of which is provided by the VAT payer.	***			

5.1.1.1.1 SelectionCriteria

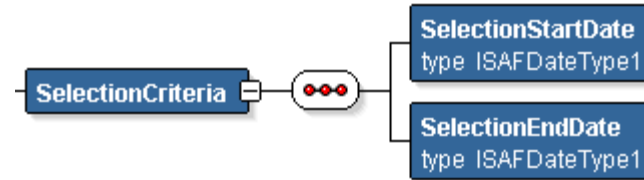
Figure No 8. i.SAF XSD -*SelectionCriteria*Table No 3. *SelectionCriteria* elements

Element index	Name of the element	Short description of the element	Explanation of the element value to be filled in and verification rules	Requirements for completion	Simple type	Type	Length
1.10.1.	<i>SelectionStartDate</i>	Start date of the tax period	Start date of the tax period.	***	ISAFDateType1	date	
1.10.2.	<i>SelectionEndDate</i>	End date of the tax period	End date of the tax period.	***	ISAFDateType1	date	

5.1.2 MasterFiles

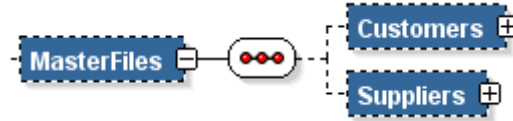
Figure No 9. i.SAF XSD - *MasterFiles*Table No 4. *MasterFiles* elements

Element index	Name of the element	Short description of the element	Explanation of the element value to be filled in and verification rules	Requirements for completion	Simple type	Type	Length
2.1.	<i>Customers</i>	Purchasers	Details of the purchasers. Only the data of the purchasers indicated in Part III of the file should be filled in.	**			
2.2.	<i>Suppliers</i>	Sellers	Details of the sellers. Only the data of the sellers listed in Part III of the file shall be completed.	**			

5.1.2.1 Customer (Customers)

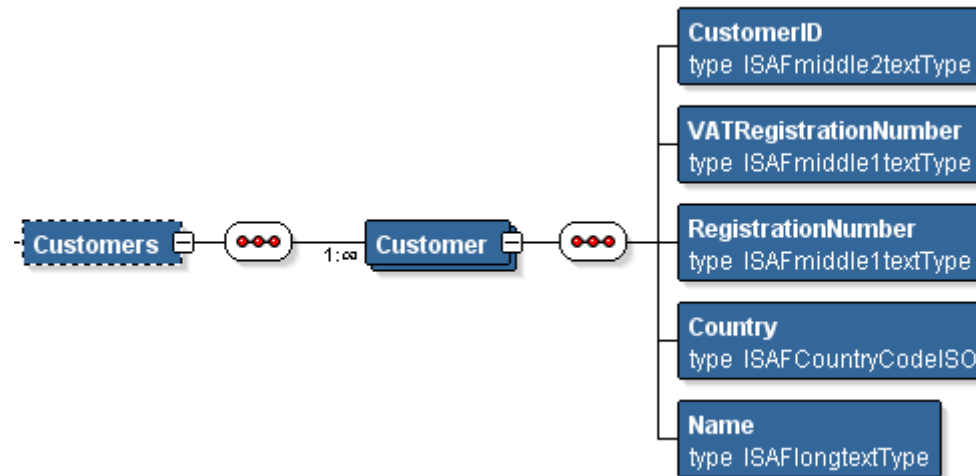
Figure No 10. i.SAF XSD - *Customer (Customers)*Table No 5. *Customer (Customers)* elements

Element index	Name of the element	Short description of the element	Explanation of the element value to be filled in and verification rules	Requirements for completion	Simple type	Type	Length
2.1.1.	<i>Customer</i>	Purchaser	Details of the purchaser.	***			
2.1.1.1.	<i>CustomerID</i>	Purchaser No	Unique purchaser's number in the entity's accounting system.	***	ISAFmiddle2textType	string	70

2.1.1.2.	<i>VATRegistrationNumber</i>	VAT identification number of the purchaser	The VAT identification number of the purchaser with a prefix shall be indicated (the VAT identification number indicated in the VAT invoice shall be indicated). If the person is not registered as a VAT payer (the VAT identification number is unknown), the element shall be completed with the value “ND” (data unavailable).	***	ISAFmiddle1textType	string	35
2.1.1.3.	<i>RegistrationNumber</i>	Registration number	The purchaser’s identification number (code) shall be the taxpayer’s code according to the Register of Taxpayers or personal identification number in a foreign state. To be filled in if “ND” is indicted in element 2.1.1.2; otherwise the element may be empty. If the purchaser does not have a VAT identification number (the value in element 2.1.1.2 is “ND” and the registration number is unknown, the element shall be filled in with the value “ND”).	*	ISAFmiddle1textType	string	35

2.1.1.4.	<i>Country</i>	Country code	Country code. A two-letter country code according to the ISO 3166-1 <i>alpha 2</i> standard, for example, LV for Latvia, shall be indicated. To be filled in if the element 2.1.1.2 indicates “ND” or a VAT identification number assigned not in the EU Member States and the identification number of the person in a foreign state in element 2.1.1.3 is indicated.	*	ISAFCountryCodeISO	string	2
2.1.1.5.	<i>Name</i>	Name	Name of the purchaser. If the name of the purchaser is not indicated in the VAT invoice, the element shall be completed with the value “ND”.	***	ISAFlongtextType	string	256

5.1.2.2 Supplier (Suppliers)

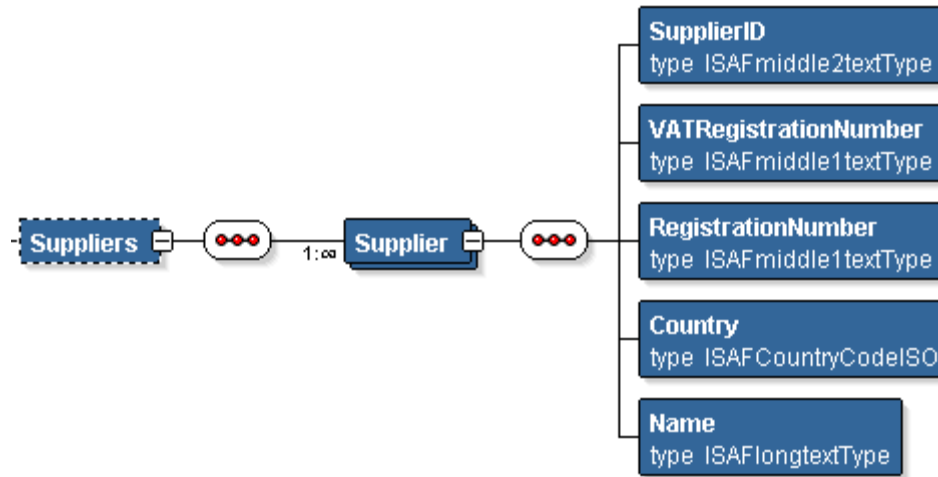
Figure No 11. i.SAF XSD - *Supplier (Suppliers)*Table No 6. *Supplier (Suppliers)* elements

Element index	Name of the element	Short description of the element	Explanation of the element value to be filled in and verification rules	Requirements for completion	Simple type	Type	Length
2.2.1	<i>Supplier</i>	Seller	Details of the seller	***			
2.2.1.1.	<i>SupplierID</i>	Seller ID	Unique number of the seller in the entity's accounting system.	***	ISAFmiddle2textType	string	70

2.2.1.2.	<i>VATRegistrationNumber</i>	VAT identification number of the seller	The VAT identification number of the seller with a prefix shall be indicated (the VAT identification number indicated in the VAT invoice shall be indicated). If the person is not registered as a VAT payer (the VAT identification number is unknown), the element shall be completed with the value "ND" (data unavailable).	***	ISAFmiddle1textType	string	35
----------	------------------------------	---	---	-----	-------------------------------------	--------	----



2.2.1.3.	<i>RegistrationNumber</i>	Registration number	The seller's identification number (code) shall be the taxpayer's code according to the Register of Taxpayers or the registration number of the farmer who is eligible for compensatory VAT rate scheme or personal identification number in a foreign state. To be filled in if "ND" is indicted in element 2.1.1.2; otherwise the element may be left empty. If the seller does not have a VAT identification number (the value in element 2.1.1.2 is "ND" and the registration number is unknown, the element shall be filled in with the value "ND").	*	ISAFmiddle1textType	string	35
----------	---------------------------	---------------------	---	---	-------------------------------------	--------	----



2.2.1.4.	<i>Country</i>	Country code	Country code. A two-letter country code according to the ISO 3166-1 <i>alpha 2</i> standard, for example, LV for Latvia, shall be indicated. To be filled in if the element 2.1.1.2 indicates “ND” or a VAT identification number assigned not in the EU Member States and the identification number of the person in a foreign state in element 2.1.1.3 is indicated.	*	ISAFCountryCodeISO	string	2
2.2.1.5.	<i>Name</i>	Name	Name of the seller. If the name of the seller is not indicated in the VAT invoice, the element shall be completed with the value “ND”.	***	ISAFLongtextType	string	256

5.1.3 SourceDocuments

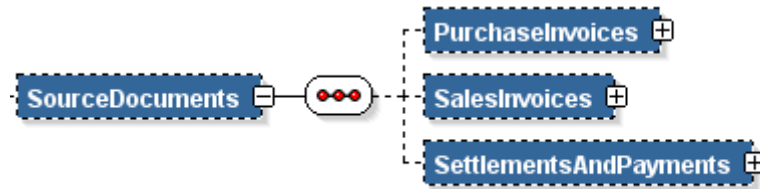
Figure No 12. i.SAF XSD - *SourceDocuments*Table No 7. *SourceDocuments* elements

Element index	Name of the element	Short description of the element	Explanation of the element value to be filled in and verification rules	Requirements for completion	Simple type	Type	Length
3.1.	<i>PurchaseInvoices</i>	Data of the register of received VAT invoices	Data of the received VAT invoice.	**			
3.2.	<i>SalesInvoices</i>	Data of the register of issued VAT invoices	Data of the issued VAT invoice.	**			

3.3.	<i>SettlementsAndPayments</i>	Details of settlements/payments	Details of settlements/payments. Where the VAT invoice is subject to the “monetary accounting system”) (special procedure for establishing the chargeable event according to Article 14(9) of the VAT Law is applicable), additional information on settlement shall be provided (the element should be filled in by the persons willing to receive the service of drawing up of a preliminary VAT return).	**			
------	-------------------------------	---------------------------------	---	----	--	--	--



5.1.3.1 Invoice (PurchaseInvoices)

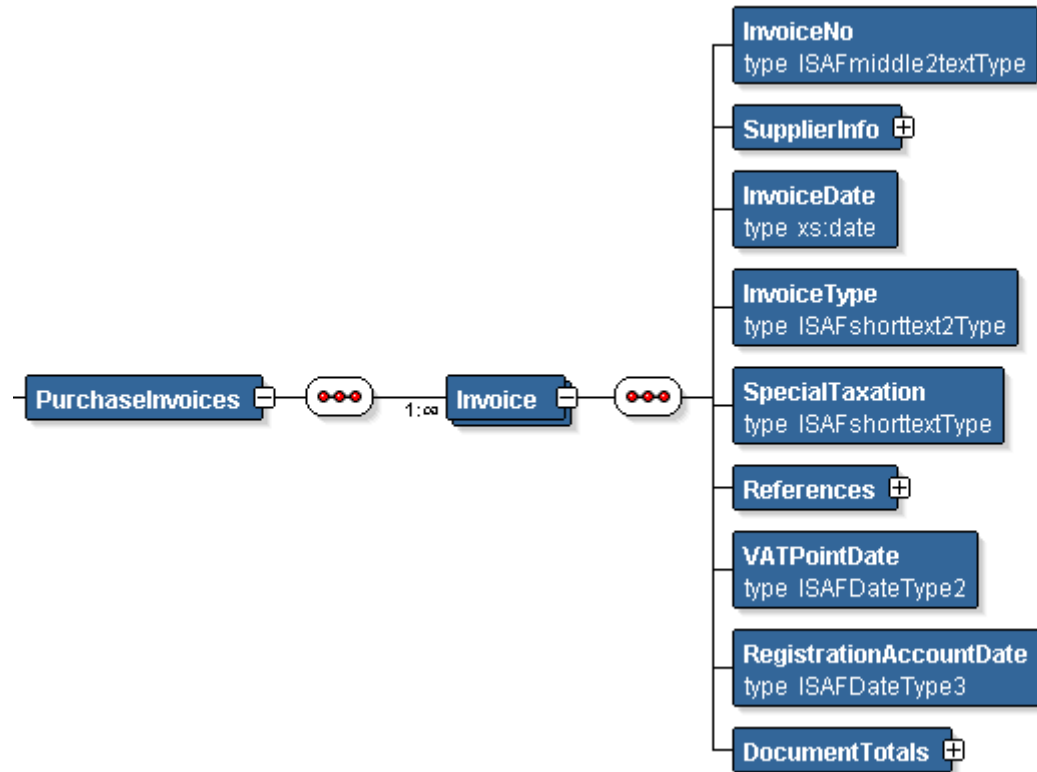

Figure No 13. i.SAF XSD - Invoice (PurchaseInvoices)

Table No 8. Invoice (PurchaseInvoices) elements

Element index	Name of the element	Short description of the element	Explanation of the element value to be filled in and verification rules	Requirements for completion	Simple type	Type	Length
3.1.1.	<i>Invoice</i>	VAT invoice.	Data on the VAT invoice.	***			
3.1.1.1	<i>InvoiceNo</i>	VAT invoice No	Series and number of the VAT invoice. It is recommended to fill in without any punctuation, space, dash or other marks, but different completion shall not be deemed to be a mistake.	***	ISAFmiddle2textType	string	70
3.1.1.2.	<i>SupplierInfo</i>	Details of the seller	Information on the seller indicated in the VAT invoice.	***			
3.1.1.3.	<i>InvoiceDate</i>	VAT invoice date	Date of issue of the VAT invoice.	***		date	

3.1.1.4.	<i>InvoiceType</i>	Type of the VAT invoice	Mark of the type of the VAT invoice: SF (or an empty element) - a VAT invoice, DS - a debit VAT invoice, KS - a credit VAT invoice, VS - one summary VAT invoice (issued by attorneys-at-law / notaries public), VD - one summary debit VAT invoice (issued by attorneys-at-law / notaries public), VK - one summary credit VAT invoice (issued by attorneys-at-law / notaries public), AN - a cancelled VAT invoice. If the value of the element is not completed, the provided information shall be deemed to refer to a VAT invoice (SF type).	*	ISAFshorttext2Type	string	2
3.1.1.5.	<i>SpecialTaxation</i>	Special taxation	Mark "T" if the VAT invoice is subject to the "monetary accounting system" (application of special procedure for establishing the chargeable event according to Article 14(9) of the VAT Law)	*	ISAFshorttextType	string	2
3.1.1.6.	<i>References</i>	References	References in credit/debit VAT invoices to adjusted invoices. If the credit/debit VAT invoices contain no references to adjusted VAT invoices, the values of the group elements shall not be filled in.	*			

3.1.1.7	<i>VATPointDate</i>	Date of receipt of goods or receipt of services	Date of receipt of goods or receipt of services if it does not coincide with the date of issue of the VAT invoice. The element value may be not filled in if the date is not indicated in the VAT invoice/not record in the accounts/coincides with the date of issue of the invoice.	*	ISAFDateType2	date	
3.1.1.8	<i>RegistrationAccountDate</i>	Date of registration in the accounts	Date of receipt of the VAT invoice or registration of the VAT invoice in the accounts. The date must fall within the tax period of the file if the date indicated in element 3.1.1.3 (date of issue of the VAT invoice) does not fall within the file tax period (the tax period of the file is established in elements 1.10.1 and 1.10.2).	*	ISAFDateType3	date	
3.1.1.9	<i>DocumentTotals</i>	Totals of the documents	Totals of the documents.	***			

5.1.3.1.1 SupplierInfo

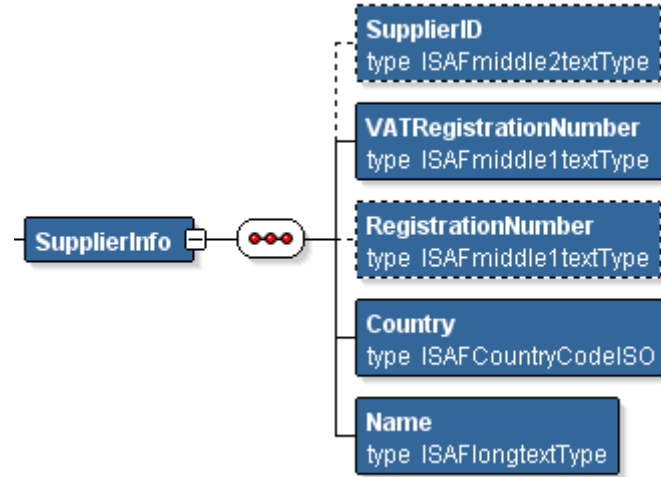

Figure No 14. i.SAF XSD - *SupplierInfo*Table No 9. *SupplierInfo* elements

Element index	Name of the element	Short description of the element	Explanation of the element value to be filled in and verification rules	Requirements for completion	Simple type	Type	Length
3.1.1.2.1.	<i>SupplierID</i>	Seller ID	Unique customer number of the seller in the entity's accounting system indicated in the master data file. To be filled in if such value is indicated in element 2.1 of Part II "Master data file" of the file / group of elements (in such case, elements 3.1.1.2.2 - 3.1.1.2.5 shall not be filled in).	**	ISAFmiddle2textType	string	70
3.1.1.2.2.	<i>VATRegistrationNumber</i>	VAT identification number of the seller	The VAT identification number of the seller with a prefix shall be indicated (the VAT identification number indicated in the VAT invoice shall be indicated). If the person is not registered as a VAT payer (the VAT identification number is unknown), the element shall be completed with the value "ND".	**	ISAFmiddle1textType	string	35

3.1.1.2.3.	<i>RegistrationNumber</i>	Registration number	The seller's identification number (code) shall be the taxpayer's code according to the Register of Taxpayers or the registration number of the farmer who is eligible for compensatory VAT rate scheme or personal identification number in a foreign state. Element 3.1.1.2.2 should be filled in if "ND" is indicted in index 3.1.1.22.; otherwise the element may be left empty. If the seller does not have a VAT identification number (the value in index 3.1.1.2 is "ND" and the registration number is unknown, the element shall be filled in with the value "ND").	**	ISAFmiddle1textType	string	35
------------	---------------------------	---------------------	---	----	-------------------------------------	--------	----



3.1.1.2.4.	<i>Country</i>	Country code	Country code. A two-letter country code according to the ISO 3166-1 <i>alpha 2</i> standard, for example, LV for Latvia, shall be indicated. To be filled in if the element index 3.1.1.2.2 indicates “ND” or a VAT identification number assigned not in the EU Member States and the identification number of the person in a foreign state in element 3.1.1.2.3 is indicated.	*	ISAFCountryCodeISO	string	2
3.1.1.2.5.	<i>Name</i>	Name	Name of the seller. If the name of the seller is not indicated in the VAT invoice, the element shall be completed with the value “ND”.	***	ISAFlongtextType	string	256

5.1.3.1.2 References

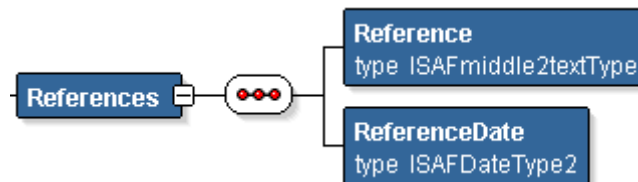

Figure No 15. i.SAF XSD - *References*

Table No 10. *References* elements

Element index	Name of the element	Short description of the element	Explanation of the element value to be filled in and verification rules	Requirements for completion	Simple type	Type	Length
3.1.1.6.1	<i>Reference</i>	Reference	A reference in a credit/debit VAT invoice to the series and number of the adjusted VAT invoice (the series and number of the adjusted VAT invoice shall be indicated).	*	ISAFmiddle2textType	string	70
3.1.1.6.2	<i>ReferenceDate</i>	Reference date	Date of issue of the adjusted VAT invoice.	*	ISAFDateType2	date	

5.1.3.1.3 DocumentTotal (DocumentTotals)

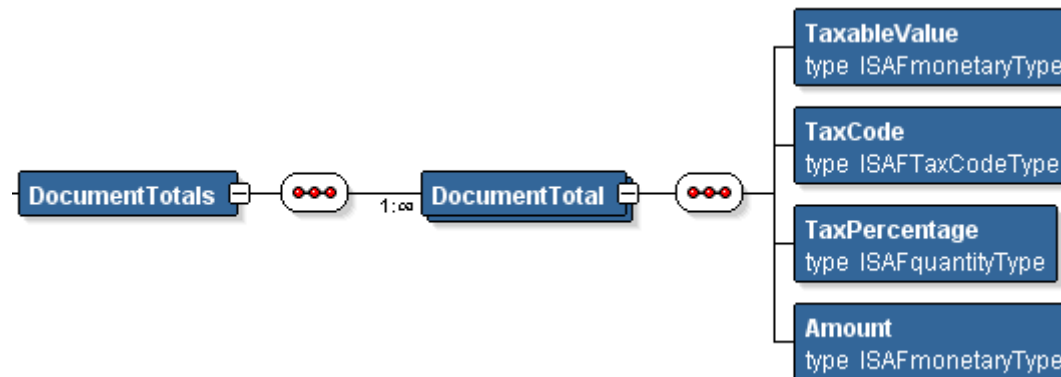

Figure No 16. i.SAF XSD - *DocumentTotal* (*DocumentTotals*)

Table No 11. *DocumentTotal* (*DocumentTotals*) elements

Element index	Name of the element	Short description of the element	Explanation of the element value to be filled in and verification rules	Requirements for completion	Simple type	Type	Length
3.1.1.9.1	<i>DocumentTotal</i>	Totals of the document	Totals of the documents.	***			
3.1.1.9.1.1	<i>TaxableValue</i>	Taxable amount	Amount of the taxable amount of all VAT invoice lines subject to the same conditions for imposition of the VAT according to the VAT classification value (according to one VAT rate).	***	ISAFmonetaryType	decimal	18 digits, with 2 digits after the decimal point

3.1.1.9.1.2	<i>TaxCode</i>	Tax code	The tax code according to the VAT classification approved by Order No VA-49 of the Head of the State Tax Inspectorate under the Ministry of Finance of the Republic of Lithuania of 21 July 2015 “On the Approval of the Technical Specification of and Technical Requirements for Standard Audit File for Tax Purposes”. The element value shall not be completed if the goods (services) are purchased from a Lithuanian VAT payer and the purchaser is not obliged to calculate, declare and/or pay the input VAT.	*	ISATaxCodeType		
3.1.1.9.1.3	<i>TaxPercentage</i>	Tax rate	The VAT rate expressed in per cent. This element may be not filled in (empty element) if no VAT rate is applicable according to the VAT classification (e.g. the supplies shall be exempt from VAT, the VAT rate applicable not in Lithuania is indicated). If the VAT rate is equal to 0%, the value 0 shall be indicated.	*	ISAFquantityType	decimal	5 digits, with 2 digits after the decimal point

3.1.1.9.1.4	<i>Amount</i>	VAT amount	VAT amount calculated on the taxable amounts of all lines of the VAT invoice subject to the same conditions for imposition of the VAT according to the value in the VAT classification (subject to the same VAT rate). The element value may be not completed if the VAT amount is not recorded in the accounts.	*	ISAFmonetaryType	decimal	18 digits, with 2 digits after the decimal point
-------------	---------------	------------	--	---	----------------------------------	---------	--



5.1.3.2 Invoice (SalesInvoices)

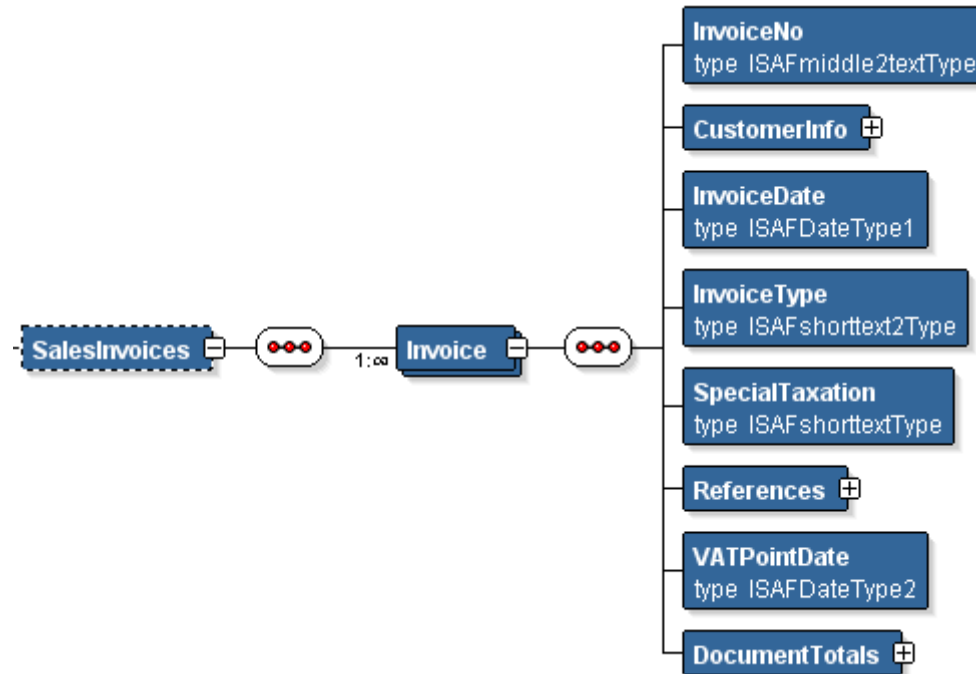

Figure No 17. i.SAF XSD - Invoice (SalesInvoices)

Table No 12. Invoice (SalesInvoices) elements

Element index	Name of the element	Short description of the element	Explanation of the element value to be filled in and verification rules	Requirements for completion	Simple type	Type	Length
3.2.1.	Invoice	VAT invoice	Data on the VAT invoice.	***			

3.2.1.1.	<i>InvoiceNo</i>	Invoice No	Series and number of the VAT invoice. It is recommended to fill in without any punctuation, space, dash or other marks, but different completion shall not be deemed to be a mistake.	***	ISAFmiddle2textType	string	70
3.2.1.2.	<i>CustomerInfo</i>	Details of the purchaser	Information on the purchaser indicated in the VAT invoice.	***			
3.2.1.3.	<i>InvoiceDate</i>	VAT invoice date	Date of issue of the VAT invoice. This date must fall within the tax period of the file (the tax period of the file is established in elements 1.10.1 and 1.10.2).	***	ISAFDateType1	date	

3.2.1.4.	<i>InvoiceType</i>	Type of the VAT invoice	Mark of the type of the VAT invoice: SF (or an empty element) - a VAT invoice, DS - a debit VAT invoice, KS - a credit VAT invoice, VS - one summary VAT invoice (issued by attorneys-at-law / notaries public), VD - one summary debit VAT invoice (issued by attorneys-at-law / notaries public), VK - one summary credit VAT invoice (issued by attorneys-at-law / notaries public), AN - a cancelled VAT invoice. If the value of the element is not completed, the provided information shall be deemed to refer to a VAT invoice (SF type).	*	ISAFshorttext2Type	string	2
----------	--------------------	-------------------------	---	---	------------------------------------	--------	---



3.2.1.5.	<i>SpecialTaxation</i>	Special taxation	Mark "T" if the VAT invoice is subject to the "monetary accounting system" (application of special procedure for establishing the chargeable event according to Article 14(9) of the VAT Law)	*	ISAFshorttextType	string	2
3.2.1.6.	<i>References</i>	References	References in credit/debit VAT invoices to adjusted invoices. If the credit/debit VAT invoices contain no references to adjusted VAT invoices, the values of the group elements shall not be filled in.	*			
3.2.1.7.	<i>VATPointDate</i>	Date of supply of goods or provision of services	Date of receipt of goods or receipt of services if it does not coincide with the date of issue of the VAT invoice. The element value may be not filled in if the date is not indicated in the VAT invoice/not record in the accounts/coincides with the date of issue of the invoice.	*	ISAFDateType2	date	

3.2.1.8.	<i>DocumentTotals</i>	Totals of the documents	Totals of the documents.	***			
----------	-----------------------	-------------------------	--------------------------	-----	--	--	--

5.1.3.2.1 CustomerInfo

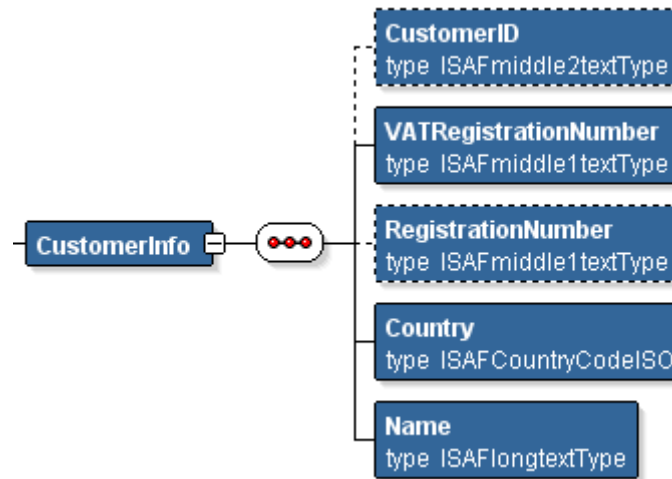

Figure No 18. i.SAF XSD - *CustomerInfo*

Table No 13. *CustomerInfo* elements

Element index	Name of the element	Short description of the element	Explanation of the element value to be filled in and verification rules	Requirements for completion	Simple type	Type	Length
3.2.1.2.1.	<i>CustomerID</i>	Purchaser ID	Unique customer number of the purchaser in the entity's accounting system indicated in the master data file. To be filled in if such value is indicated in element 2.2 of Part II "Master data file" of the file / group of elements (in such case, elements 3.2.1.2.2 - 3.2.1.2.5 shall not be filled in).	**	ISAFmiddle2textType	string	70

3.2.1.2.2.	<i>VATRegistrationNumber</i>	VAT identification number of the purchaser	The VAT identification number of the purchaser with a prefix shall be indicated (the VAT identification number indicated in the VAT invoice shall be indicated). If the person is not registered as a VAT payer (the VAT identification number is unknown), the element shall be completed with the value "ND".	**	ISAFmiddle1textType	string	35
3.2.1.2.3.	<i>RegistrationNumber</i>	Registration number	The purchaser's identification number (code) shall be the taxpayer's code according to the Register of Taxpayers or personal identification number in a foreign state. To be filled in if "ND" is indicated in element 3.2.1.2.2; otherwise the element may be left empty. If the seller does not have a VAT identification number (the value in element 3.2.1.2.2 is "ND" and the registration number is unknown), the element shall be filled in with the value "ND".	**	ISAFmiddle1textType	string	35

3.2.1.2.4.	<i>Country</i>	Country code	Country code. A two-letter country code according to the ISO 3166-1 <i>alpha 2</i> standard, for example, LV for Latvia, shall be indicated. To be filled in if the element index 3.2.1.2.2 indicates “ND” or a VAT identification number assigned not in the EU Member States and the identification number of the person in a foreign state in element 3.2.1.2.3 is indicated.	*	ISAFCountryCodeISO	string	2
3.2.1.2.5.	<i>Name</i>	Name	Name of the purchaser. If the name of the purchaser is not indicated in the VAT invoice, the element shall be completed with the value “ND”.	***	ISAFLongtextType	string	256

5.1.3.2.2 References

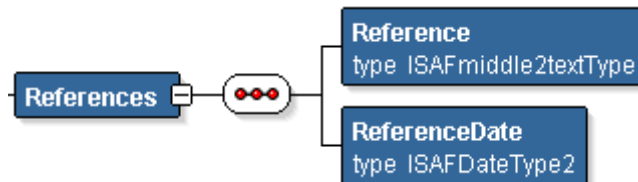

Figure No 19. i.SAF XSD - *References*

Table No 14. *References* elements



Element index	Name of the element	Short description of the element	Explanation of the element value to be filled in and verification rules	Requirements for completion	Simple type	Type	Length
3.2.1.6.1.	<i>Reference</i>	Reference	A reference in a credit/debit VAT invoice to the series and number of the adjusted VAT invoice (the series and number of the adjusted VAT invoice shall be indicated).	*	ISAFmiddle2textType	string	70
3.2.1.6.2	<i>ReferenceDate</i>	Reference date	Date of issue of the adjusted VAT invoice.	*	ISAFDateType2	date	

5.1.3.2.3 DocumentTotal (DocumentTotals)



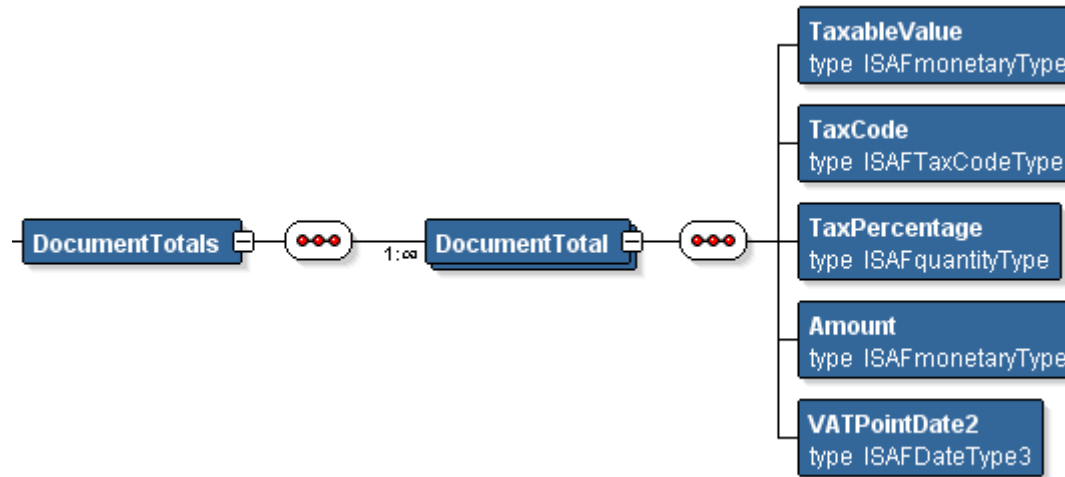

Figure No 20. i.SAF XSD - DocumentTotal (DocumentTotals)

Table No 15. DocumentTotal (DocumentTotals) elements

Element index	Name of the element	Short description of the element	Explanation of the element value to be filled in and verification rules	Requirements for completion	Simple type	Type	Length
3.2.1.8.1	DocumentTotal	Totals of the document	Totals of the documents.	***			
3.2.1.8.1.1	TaxableValue	Taxable amount	Amount of the taxable amount of all VAT invoice lines subject to the same conditions for imposition of the VAT according to the VAT classification value (according to one VAT rate).	***	ISAFmonetaryType	decimal	18 digits, with 2 digits after the decimal point

3.2.1.8.1.2	<i>TaxCode</i>	Tax code	The tax code according to the VAT classification approved by Order No VA-49 of the Head of the State Tax Inspectorate under the Ministry of Finance of the Republic of Lithuania of 21 July 2015 “On the Approval of the Technical Specification of and Technical Requirements for Standard Audit File for Tax Purposes”.	***	ISATaxCodeType		
3.2.1.8.1.3	<i>TaxPercentage</i>	Tax rate	The VAT rate expressed in per cent. This element may be not filled in (empty element) if no VAT rate is applicable according to the VAT classification (e.g. the supplies shall be exempt from VAT, the VAT rate applicable not in Lithuania is indicated). If the VAT rate is equal to 0%, the value 0 shall be indicated.	*	ISAFquantityType	decimal	5 digits, with 2 digits after the decimal point

3.2.1.8.1.4	<i>Amount</i>	VAT amount	VAT amount calculated on the taxable amounts of all lines of the VAT invoice subject to the same conditions for imposition of the VAT according to the value in the VAT classification (subject to the same VAT rate). The element value may be not completed if the VAT amount is not recorded in the accounts.	*	ISAFmonetaryType	decimal	18 digits, with 2 digits after the decimal point
3.2.1.8.1.5	<i>VATPointDate2</i>	Date of receipt of goods or receipt of services	Date of receipt of goods or receipt of services if it does not coincide with the date of issue of the VAT invoice. The element value may be not filled in if the date is not indicated in the VAT invoice/not record in the accounts/coincides with the date of issue of the invoice.	*	ISAFDateType3	date	

5.1.3.3 SettlementsAndPayment (SettlementsAndPayments)

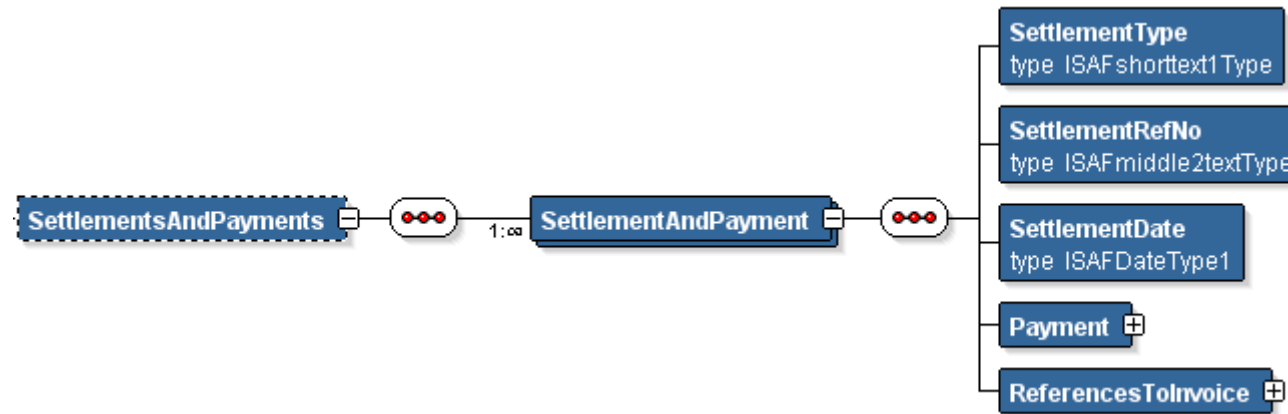

Figure No 21. i.SAF XSD - SettlementsAndPayment (SettlementsAndPayments)

Table No 16. SettlementsAndPayment (SettlementsAndPayments) elements

Element index	Name of the element	Short description of the element	Explanation of the element value to be filled in and verification rules	Requirements for completion	Simple type	Type	Length
3.3.1.	<i>SettlementAndPayment</i>	Payment or received settlement	Data on payment or received settlement.	***			
3.3.1.1.	<i>SettlementType</i>	Type of payment	Mark of the type of payment (G - received payment, V - made payment).	***	ISAFshorttext1Type	string	2

3.3.1.2.	<i>SettlementRefNo</i>	Payment document No	Number of the payment document (payment order to the bank, cash document). If the number of the payment document is unknown (in case of receipt, the type of payment G), the filled in value of the element should be “ND”.	*	ISAFmiddle2textType e	string	70
3.3.1.3.	<i>SettlementDate</i>	Date of settlement	Actual date of receipt/payment of money. The date must fall within the tax period of the file (the tax period of the file is established in elements 1.10.1 and 1.10.2).	***	ISAFDateType1	date	
3.3.1.4.	<i>Payment</i>	Details of the seller or the purchaser	Details of the seller or the purchaser. Information on the purchaser shall be fill in if the type G (received payment) is indicated in element 3.3.1.1. Information on the seller (in case of payment) is filled in if element 3.3.1.1 indicates the type V (made payment).	***			

3.3.1.5.	<i>ReferencesToInvoice</i>	References to the VAT invoices for which the payment is made	Information of VAT invoices.	***			
----------	----------------------------	--	------------------------------	-----	--	--	--

5.1.3.3.1 Payment

Figure No 22. i.SAF XSD - *Payment*

Table No 17. *Payment* elements

Element index	Name of the element	Short description of the element	Explanation of the element value to be filled in and verification rules	Requirements for completion	Simple type	Type	Length
3.3.1.4.1.	<i>SupplierCustomer ID</i>	Seller or purchaser ID in his accounting system	Unique customer number of the seller or the purchaser in the entity's accounting system indicated in the master data file. To be filled in if such value is indicated in element 2.1 or 2.2 of Part II "Master data file" of the file / group of elements (in such case, elements 3.3.1.4.2-3.3.1.4.5 shall not be filled in).	**	ISAFmiddle2textType	string	70
3.3.1.4.2.	<i>VATRegistrationNumber</i>	VAT identification number of the seller or purchaser	The VAT identification number of the seller or the purchaser with a prefix shall be indicated (the VAT identification number indicated in the VAT invoice shall be indicated). If the person is not registered as a VAT payer, the element shall be completed with the value "ND".	**	ISAFmiddle1textType	string	35

3.3.1.4.3.	<i>RegistrationNumber</i>	Registration number	The identification number (code) of the seller or the purchaser shall be the taxpayer's code according to the Register of Taxpayers or personal identification number in a foreign state. To be filled in if "ND" is indicted in element 3.3.1.4.2; otherwise the element may be left empty. If the seller does not have a VAT identification number (the value in element 3.3.1.4.2 is "ND"), the element shall be filled in with the value "ND".	**	ISAFmiddle1textType	string	35
3.3.1.4.4.	<i>Country</i>	Country code	Country code. A two-letter country code according to the ISO 3166-1 <i>alpha 2</i> standard, for example, LV for Latvia, shall be indicated. To be filled in if the element index 3.3.1.4.2 indicates "ND" or a VAT identification number assigned not in the EU Member States and the identification number of the person in a foreign state in element 3.3.1.4.3 is indicated.	*	ISAFCountryCodeISO	string	2

3.3.1.4.5.	<i>Name</i>	Name	Name of the seller or purchaser. If the name of the purchaser is not indicated in the payment document and not recorded in the accounts, the value “ND” shall be indicated.	***	ISAFlongtextType	string	256
------------	-------------	------	---	-----	----------------------------------	--------	-----

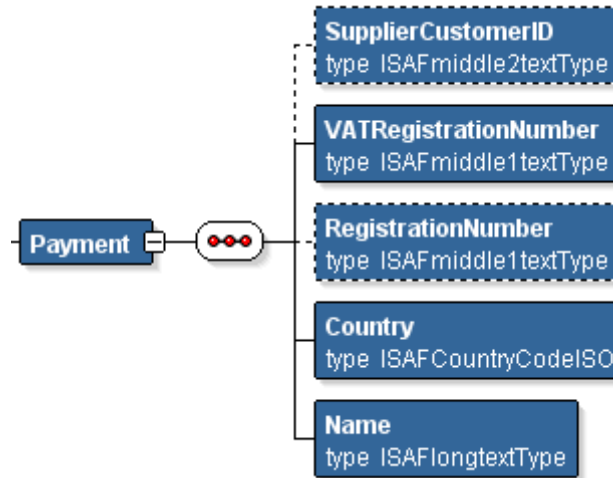
5.1.3.3.2 ReferencesToInvoice

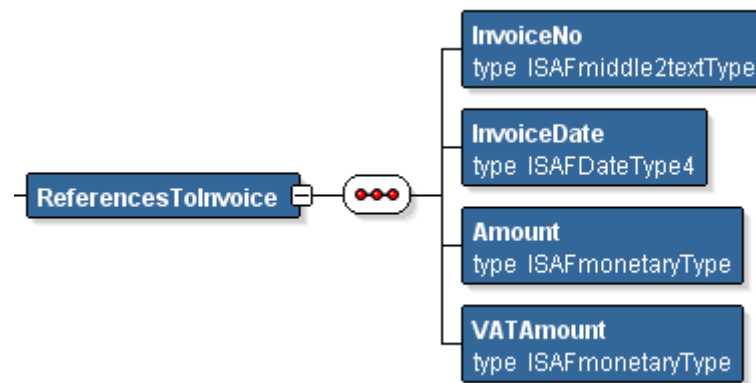

Figure No 23. i.SAF XSD - *ReferencesToInvoice*

Table No 18. *ReferencesToInvoice* elements

Element index	Name of the element	Short description of the element	Explanation of the element value to be filled in and verification rules	Requirements for completion	Simple type	Type	Length
3.3.1.5.1.	<i>InvoiceNo</i>	VAT invoice No	Series and number of the VAT invoice.	***	ISAFmiddle2textType	string	70
3.3.1.5.2.	<i>InvoiceDate</i>	Date of the VAT invoice	Date of issue of the VAT invoice.	***	ISAFDateType4	date	
3.3.1.5.3.	<i>Amount</i>	Taxable amount	Paid taxable amount or any part thereof (excluding VAT).	***	ISAFmonetaryType	decimal	18 digits, with 2 digits after the decimal point
3.3.1.5.4.	<i>VATAmount</i>	VAT amount	Paid taxable amount or any part thereof.	***	ISAFmonetaryType	decimal	18 digits, with 2 digits after the decimal point

5.2 Description of simple types

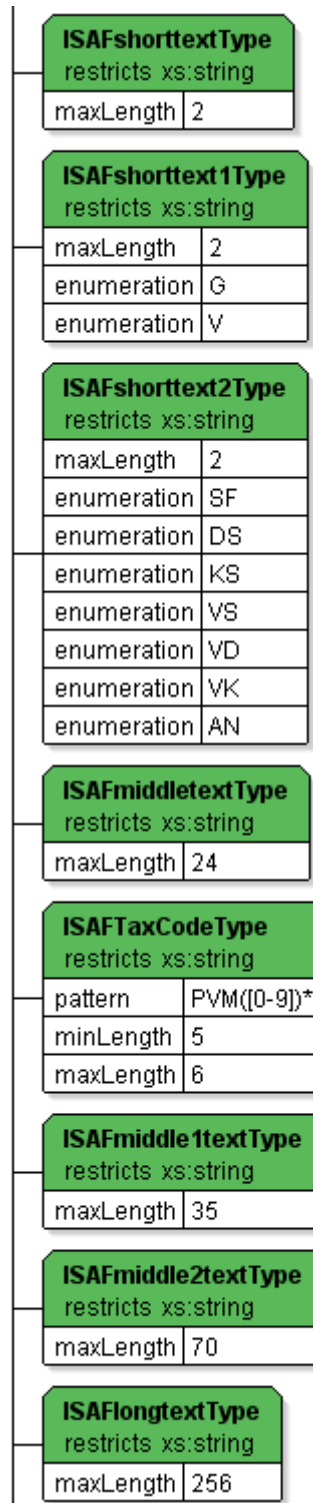

Figure No 24. Simple types (1)

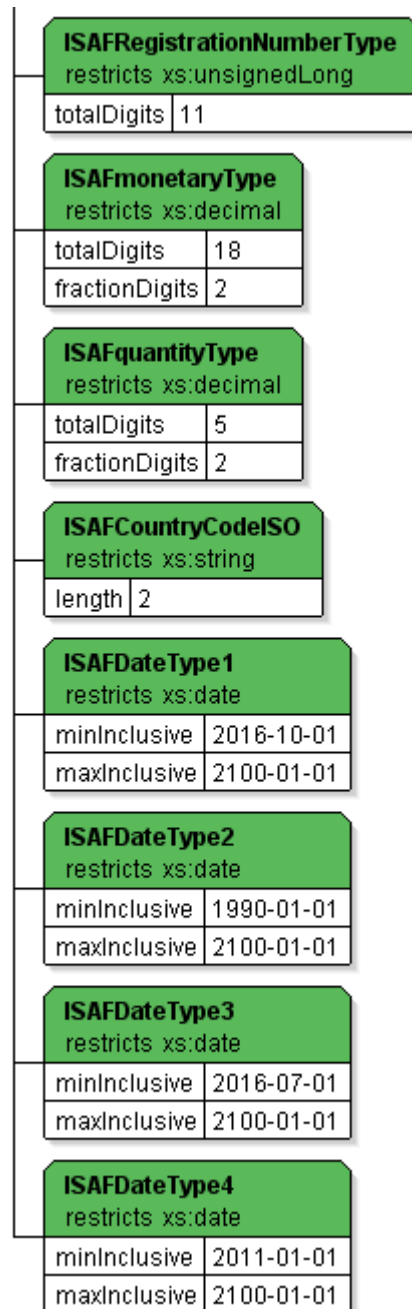

Figure No 25. Simple types (2)

Table No 19. Simple types

Name	Type	Description
ISAFshorttextType	string(2)	
ISAFshorttext1Type	string(2)	
ISAFshorttext2Type	string(2)	
ISAFTaxCodeType		
ISAFmiddletextType	string(24)	
ISAFmiddle1textType	string(35)	
ISAFmiddle2textType	string(70)	
ISAFlongtextType	string(256)	
ISAFRegistrationNumberType		11
ISAFmonetaryType	decimal	18 digits, with 2 digits after the decimal point

ISAFquantityType	decimal	5 digits, with 2 digits after the decimal point
ISAFCountryCodeISO	String(2)	
ISAFDateType1	date	Date can be from 01-10-2016 to 01-01-2100
ISAFDateType2	date	Date from 01-01-1990 to 01-01-2100
ISAFDateType3	date	Date from 01-07-2016 to 01-01-2100
ISAFDateType4	date	Date from 01-01-2011 to 01-01-2100

